



Provides next generation pattern tracing—maximizing quality, speed and reliability

- Advanced video image-capture technology provides the highest resolution pattern tracing system available today
- Advanced RISC processor and software design provides superior tracing performance
- Advanced imaging with real-time video processing
- Solid-state electronic design provides maximum reliability
- Enhanced flexibility with versatile tracing modes
- Both center-of-line and edge tracing modes

Performance Benefits

The Replicator® CCD is the most technologically advanced template following system available today. It is available from Cleveland Motion Controls and part of the BURNY® product family, an internationally recognized line of dedicated shape-cutting controls and control systems that improve productivity and reduce costs.

Users can count on faster and more accurate tracing speeds, limited only by the cutting machine mechanics—not the system electronics. By eliminating all moving parts, it is more reliable than conventional tracers. Maximum flexibility is provided with both center-of-line and edge tracing modes. In addition, with built-in self-diagnostics, the Replicator CCD quickly evaluates the performance of all subsystems, making set-up faster and easier, with more information available to users than ever before.

Design Features

The Replicator CCD incorporates a revolutionary new design, featuring the advanced technology of CCD video image-capture for high quality pattern tracing. A high-speed RISC (Reduced Instruction Set Computer) processor provides image processing of software algorithms. An advanced FPGA (Field Programmable Gate Array) provides real-time video processing and data compression algorithms. Combined, the new image recognition and processing software provides the most accurate video-enhanced pattern tracing possible.

REPLICATOR CCD PATTERN TRACING SYSTEM

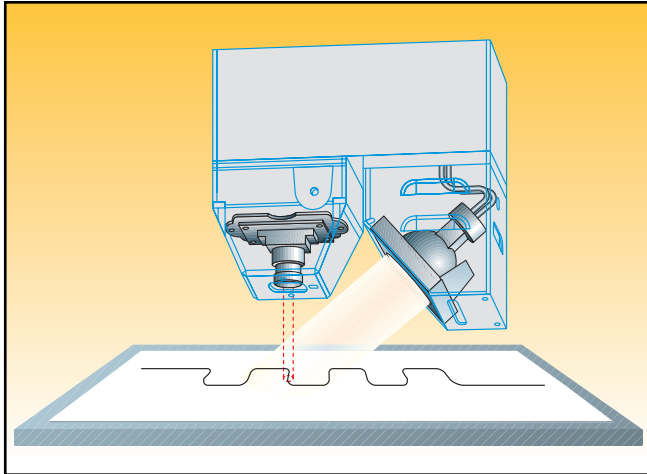

Design Features	Performance Benefits
Revolutionary new design utilizing CCD camera and microprocessor control	An advanced technology platform, providing a state-of-the-art, high-tech tracing system.
RISC microprocessor	Provides 130 Mhz CPU performance to support sophisticated image-processing algorithms.
Solid state design	Assures reliability and longevity due to solid state design (and no moving parts).
Custom image processing software	Automatically adapts to pattern variations to reduce tracing errors caused by minor pattern problems
FLASH ROM storage of software	System software is easily updated.
Advanced FPGA custom chip	Performs real-time video enhancement and data compression algorithms implemented in software.
Compact size	Compact size facilitates easy mounting and various applications

Hardware and Operational Specifications

Operating temperature 0 – 50 degrees C Relative humidity 5% - 95%, non-condensing	Replicator CCD image-capture tracer is designed to withstand the harsh elements of the production floor through a wide range of operating temperature environments.
Super-bright targeting LED	Targeting LED used to provide an easy means for leading into pattern.
Template lighting uses halogen light bulb	Easily accessible and changeable bulb.

Performance and Operational Features

Diagnostics capability	Provides detailed diagnostic messages and allows BURNY Replicator CCD performance status to be evaluated objectively.
Kerf offset	Adjustable for cuts up to 6.0 mm wide
Front panel adjustable kerf	Easily accessible kerf adjustment allows kerf to be adjusted to left or right of line.
Software algorithm automatic corner slowdown	Sophisticated corner slowdown algorithm automatically looks ahead and applies adjustable slowdown, producing optimum cornering characteristics.
Automatic look-ahead	Look-ahead is dynamically and automatically adjusted by the image-processing algorithms.
Built-in self diagnostics	Power on self test identifies problems and displays easy-to-interpret error codes. Eases set-up and reduces downtime.
Large CCD area of view	Allows faster tracing speeds.
±0.5 inch (12.5 mm) template height tolerance	Long depth of field camera lens allows for variations in template height or mounting distance to be accommodated.
Fast motor control update rate	Fast motor control update rate assures accurate and repeatable tracing.
Extensive self test modes <ul style="list-style-type: none"> ▪ CPU test ▪ Flash ROM test ▪ Setup parameter checksum verification ▪ DRAM test ▪ Integrated peripherals test ▪ Power supply test ▪ DAC and ADC test ▪ UART test ▪ Pushbutton test ▪ Image capture test ▪ Targeting LED test ▪ Illumination source test 	Power on test evaluates the performance of all primary subsystems during system boot up. PC interface allows more sophisticated diagnostics to be run if needed.

Template Capabilities

Edge tracing mode – Traces edge of line with automatic corner slowdown.	Templates can be prepared in various configurations to suit application requirements in edge, center line and silhouette methods, facilitating maximum flexibility and template preparation.
Center line tracing mode	Traces center of line, no automatic feed rate reduction.
Silhouette tracing mode—Traces the outline of a solid (filled) pattern	Allows solid pattern to be traced.
Line width – Minimum .7 mm	
Automatically adjusts forward offset to optimum value as a result of desired/set tracing speed.	Forward offset is automatically determined by the software parameter—no need for a manual adjustment.

BURNY PRODUCTS

World Headquarters
7550 Hub Parkway
Cleveland, OH 44125-5794
Phone: (216) 524-8800 or
(800) 321-8072
Fax: (216) 642-2199

**etek Industrie-
Elektronik GmbH**
Werkstrasse 5
D-64732 Bad König, Germany
Phone: 49 (0) 6063-9314-0
Fax: 49 (0) 6063-5492

An IMC Company